



LPD100H

Portable Hydraulic Drive DTH Drilling Machine

Super portable & Super lightweight



LEAD EQUIPMENT CO., LTD.

Description

LPD100H is portable hydraulic chain feed drilling machine, ideal for all handy drilling work; It can be used with down-the-hole hammer and drill hammer as well as for core drilling. Designed for easy mounting on any type of scaffolding and suitable for wall work. Very light and handy.

Application

Hydraulic portable chain feed drilling machine is widely used for the below project:

- Nailing
- Core Drilling
- Blast Holes
- Exploratory Drilling
- Micropiles
- Diamond Drilling



Technical Data

Model	LPD100H
Hole Diameter	80~120mm
Hole Depth	30m
Feed Force	12KN
Rotate Speed	90~120rpm
Torque	1000NM
Air Pressure	0.5~0.7Mpa
Air consumption	7~8m ³ /min
Single feeding distance	1m
Drilling Direction	Any Angle
Weight	86Kg (Only drill machine)
Dimension	2230x560x415mm

Construction and dimensions

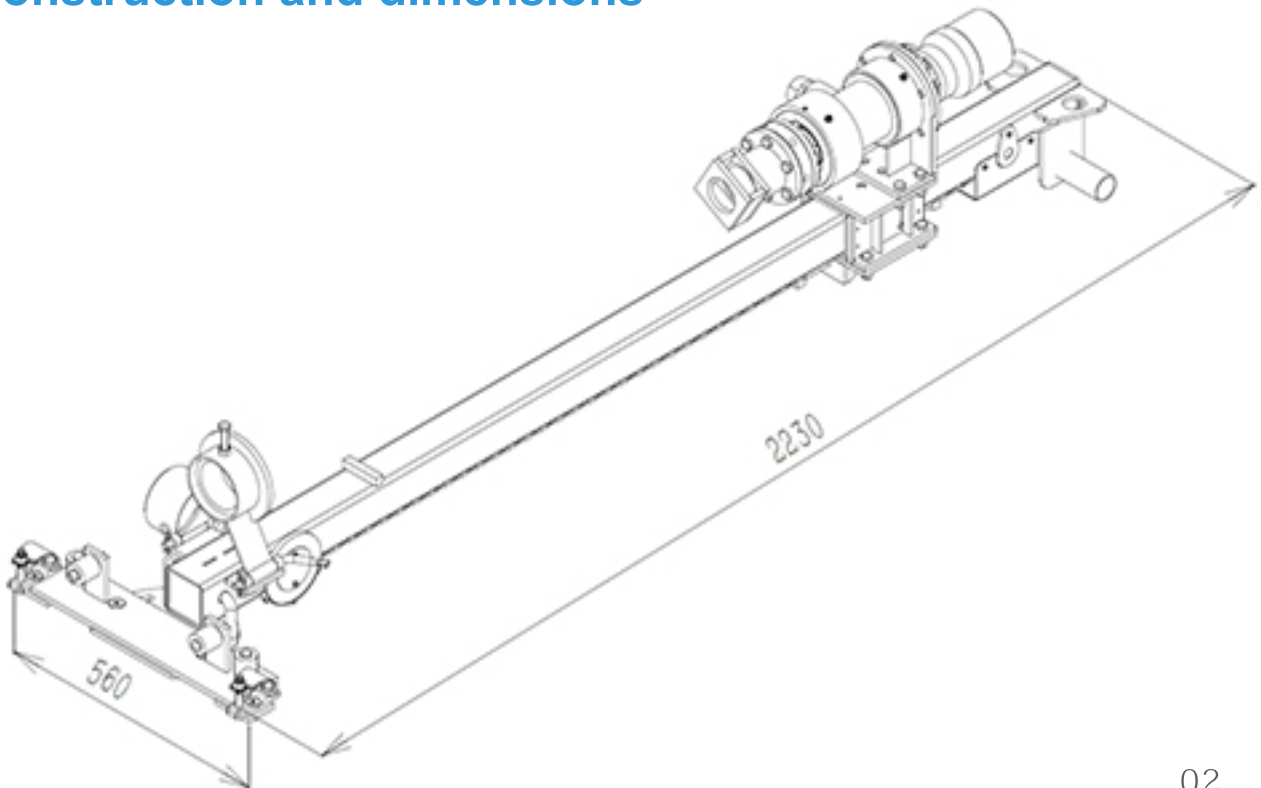

Diesel Drive Hydraulic station

Hydraulic station is driven by diesel engine, equipped with cooling system, filtration system, pressure regulating system, pressure and temperature indication and valve control. The product is compact, easy to operate and does not take up space.

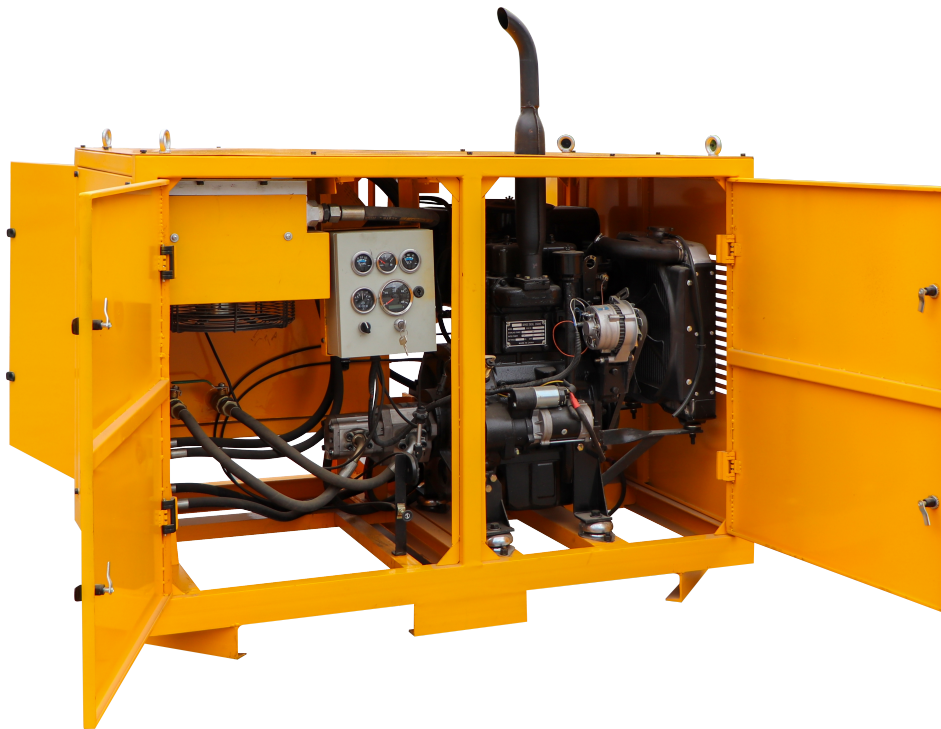

Technical Data

Description	Parameter
Type	BHPP15/55X2-30D
Output capacity	2 × 55L/min
Outlet pressure	15MPa
Diesel power	Weichai 2110 26KW
Dimensions	1760X1150X1300mm
Weight	960kg

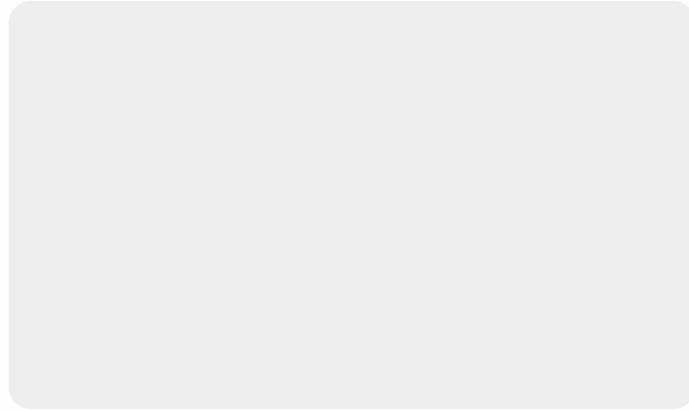

Lead Equipment Co., Ltd.

Xisihuan Ring-Road East, Tielu, Xiliu Lake sub-district,
Zhongyuan District, Zhengzhou, Henan China

P.C.: 450000 Tel: +86-371-63902781

Mobile/WhatsApp/Viber: +86-18538591025

Fax: +86-371-63526675

Email: sales@leadcrete.com

Website: www.leadcrete.com/www.leadcrete.net

