

LGP300-300-75PI-E Grout Plant



Description

LGP300/300/75PI-E China compact grout plant is combination of mixer, rectangular agitator and piston grout pump in one plant. It is mainly used in municipal, highway, railway, hydropower, construction, mining and other construction site for grouting.

A high shear mixer is used to obtain cement paste through the intense mixing of water and cement or bentonite. The obtained mix is transported into an agitator.

An agitator, which maintains in suspension mixes such as cement mortar or bentonite clay. Then grouting pump absorbs cement paste from agitator. Because of using rectangular agitator, makes the plant with smaller boundary dimension.

Grouting pump is designed for double-acting piston, so discharge of grouting pump is continuous, uniform and smaller pulse. The grouting pump adopts the full hydraulic drive. Grouting pressure and output are step-less adjustable and grouting pump has high speed and low speed by rotating ball valve switch.

Feature

1. Hydraulic reversing and Hydraulic drive for Vertical grouting pump;
2. Grouting pressure and output are step-less adjustable;
3. Using rectangular agitator, makes the plant has compact structure, small size;
4. Grouting pump has high speed and low speed by rotating ball valve switch;
5. With the function of record and display grouting pump reciprocating times by a counter;
6. With an air cooler and a water cooler, to adapt to different working environment temperature;
7. Mixer and agitator switch is a squeeze handle that is easy to operate and reliable;

Applications

1. **Civil Engineering** - dam foundations, tunnels, mining, soil nails, tiebacks, earth anchors, cable and rock bolts;
2. **Structural** – building and bridge restoration, foundation stabilization, foundation raising, soil compaction grouting; soil & rock grouting;
3. **Construction** - pavement under sealing, slab jacking and slab raising;
4. **Marine** - underwater foundations, piers, breakers, shoreline foundations;
5. **Mining** - tunnel lining, contact grouting, shaft waterproofing;
6. **Utilities** - encasements, waterproofing, slope line grouting;
7. **Geotechnical** - deep well casing, monitor wells, well sealing and abandonment;

Type

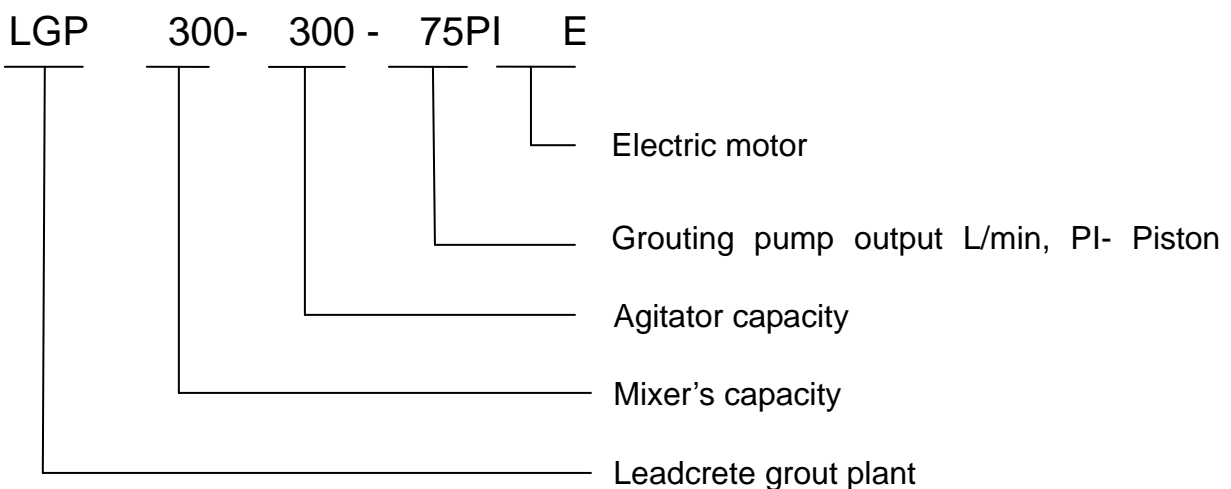

Technical data

Description	Data
Grout Station model	LGP300/300/75PI-E
Dimensions	2330x1260x1790mm
Weight	1125kg
Mixer	
Capacity	300L
Output	4.5m ³ /h
Power	7.5Kw, 1450rpm,50Hz,380V
Rated Rev	1450rpm
W/C	≥0.5~1
Agitator	
Capacity	300L
Rated Rev.	36rpm
Power	1.5KW, 50Hz, 50HZ, 380V
Pump	
Output and pressure	0-75L/min, 0-5Mpa(high-speed)
	0-38L/min, 0-10MPa(low-speed)
Power	11kw, 50Hz,380V

Picture





Zhengzhou Lead Equipment Co., Ltd.

Add: Xisihuan Ring-Road East, Tielu, Xiliu lake sub-district, Zhongyuan District, Zhengzhou, Henan

Web: www.leadcrete.com

E-Mail: sales@leadcrete.com

TEL.:+86-371-63902781

FAX:+86-371-63526676