

LGP400/1000/95/165DPL-E/A Grout mixer and pump with wheels

Powerful, Compact and Reliable

1. Description



LGP400/1000/95/165DPL-E/A Grout mixer and pump with wheels are integrated with a screw feeder, mixing, agitator and horizontal hydraulic pump. It is mainly used to be made such as cement slurry or bentonite slurry, etc., for injecting in the sub-soil for soil consolidation, piling or even for long transport of material.

Compared with the traditional grout mixer and pump machine, LGP400/1000/95/165DPL-E/A Grout mixer and pump with wheels has several advantages: high-speed, high-shear colloidal mixer causes a vortex flow to ensure mix quickly and evenly; Two pieces of high pressure plungers to stabilize the consistency of the grouting flow; Grouting pressure and displacement is step-less adjustable; Added the automatic operation mode, which greatly improves the working efficiency. Besides, compact size and easy to operate. And it also takes up a small space. Therefore, this machine is widely used in mines, tunnels, culverts, subways, hydropower projects, underground projects, etc.

2. Features

LGP400/1000/95/165DPL-E/A Grout mixer and pump with wheels is a fully automatic grouting machine.



MIXER STATION

- ◆ 3 sets of stable weighing modules

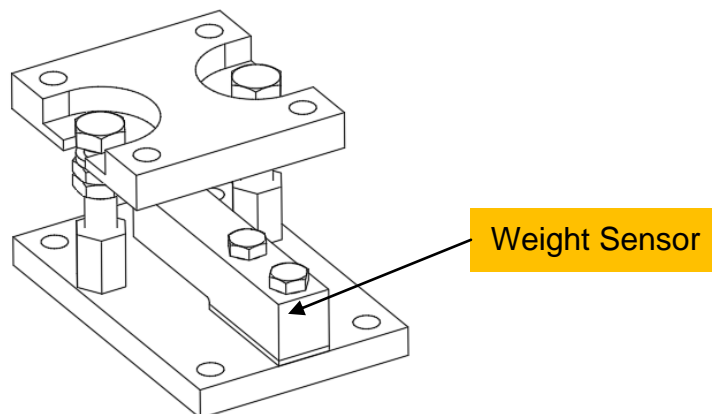

- ◆ Lower charging material height for mixer
- ◆ High-speed colloidal grout mixer
- ◆ Smoothly outflow slurry through pneumatic pinch valve

◆ Precision of the ultrasonic liquid level meter

◆ PLC machine control

Visualization interface

Simple operation interface

Manual mode and fully automatic mode

Multiple formulations can be set up



GROUT PUMP STATION

◆ Grouting pressure, displacement is step-less adjustable

◆ Simple structure, light weight, easy maintenance

◆ Double grouting plungers, continuous output flow with less pulse

◆ Less spare parts ensure low maintenance costs

◆ With the function of record and display grouting pump reciprocating times by a counter



Adjustable output with this valve
(LS control)

High pressure piston hydraulic pump
(LS control)

- ◆ The motor has an overload protection function. Hydraulic system with oil temperature overheating protection
- ◆ Electric motor and hydraulic driven. Anytime, overpressure occurred, the hydraulic safety protection will be worked

3. Technology Sheet

Specification (with Electric motor drive):	
1. Mixer Station	
1.1 Pneumatic Pinch Valve: the slurry flows more smoothly;	
1.2 Ultrasound Fluid Level Meter: height of agitator can be accurately measured;	
1.3 PLC+Touch Screen: manual mode and fully automatic mode.	
2. Grout Pump Station	
2.1 Grouting pressure, displacement is step-less adjustable;	
2.2 Double grouting plungers, continuous output flow with less pulse;	
2.3 With the function of record and display grouting pump reciprocating times by a counter;	
2.4 The motor has an overload protection function;	
2.5 Hydraulic system with oil temperature overheating protection;	
2.6 Electric motor and hydraulic driven. Anytime, overpressure occurred, hydraulic safety protection will be worked.	
3. Trailer	
3.1 With steering function;	
3.2 Tripod height is adjustable.	

Mixer Station		
Mixer	Effective Volume	400 L
	Max. Mixing Capacity	10m ³ /h
Circulation Pump	Motor Power	11 Kw
	Rotating Speed	1450 r/min
	Circulation Capacity	1000L/min
Agitator	Effective Volume	1000 L
	Motor Power	3.0 Kw
Water Supply System	Motor Power	4.0 Kw
	Displacement	20 m ³ /h
	Head	30 m
Air Supply System	Motor Power	2.2 Kw
	Displacement	0.25 m ³ /h
Control System	Mode	PLC
	Power	DC 24V

Grout Pump Station		
Plunger Diameter	85mm	
Plunger Stroke	300mm	
Adjustable Pressure	0-16.5MPa	
Adjustable Flow Rate	0-95L/min	
Discharge Pipe Size	G1 1/4 "	
Inlet Pipe Size	G2 "	
Oil Tank	200L	
Power Unit	37Kw	
Max. Grain Size	2mm	
Working Pressure	16.5MPa	
Dimension(LxWxH) without Screw Feeder@Weight	3820x2280x2300mm@3750Kg	
Screw Feeder	Output	30t/h
	Motor	5.5Kw
	Dimension@Weight	3700x600x800mm@280Kg
<p>We also could accord to your demands to customize. All parameters are obtained by water test.</p>		

4. Machine Pictures Gallery



Zhengzhou Lead Equipment Co., Ltd.

Add: Xisihuan Ring-Road East, Tielu, Xiliu lake sub-district,
Zhongyuan District, Zhengzhou, Henan

Web: <https://www.leadcrete.net>

E-Mail: sales1@leadcrete.com