

LSZ-10S/E Electric motor dry and wet shotcrete machine



◆ Description

LSZ-10S/E Electric motor dry and wet shotcrete machine is a multifunctional rotor type machine for wet and dry spraying and conveying. The materials that can be sprayed and conveyed are concrete, mortar, refractory, sand, pea gravel and crushed stone.

Compared with traditional shotcrete machines, LSZ-10S/E has the advantage of being lighter and more compact. In addition, LSZ-10S/E is equipped with a rubber sealing plate lubrication system, which can effectively reduce the wear of rubber plates, longer service life and better sealing effect.

◆ Advantages and benefits

1. Theoretical displacement can be adjusted.
2. Easily overcome obstacles of long or high conveying distances (dry mix).
3. Less dust development.
4. Equipped with an automatic lubrication system, the rubber plate has a longer service life.
5. For concrete repair, slope stabilization, excavation support, or mining.
6. Light and compact machine design.

◆ The main structure

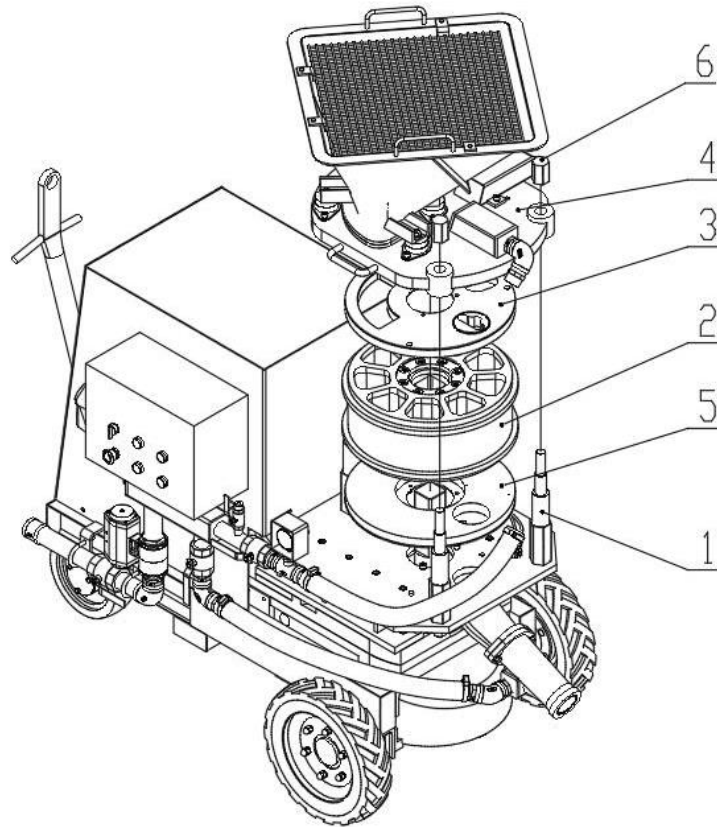

1	Modify clamp
2	Rotor
3	Upper rubber plate
4	Hopper seat
5	Lower rubber plate
6	Clamp

◆ Dimension

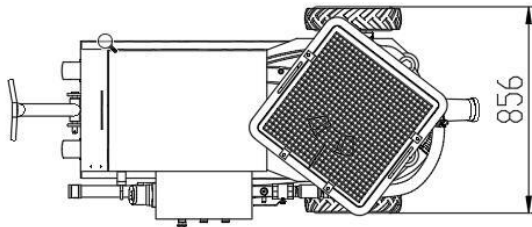
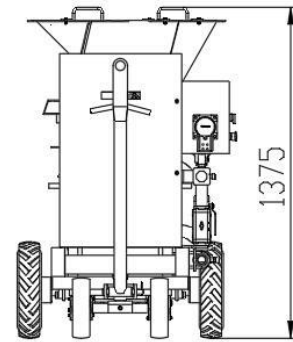
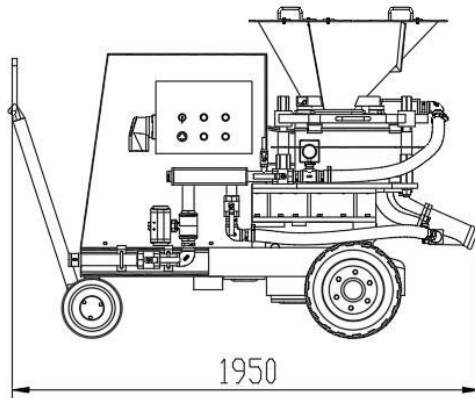

◆ **Technical specifications**

Name	Data	
Machine type	LSZ-10S/E	
Power supply	AC380V 50Hz three-phase	
Motor power	7.5kw	
Air consumption	10 m ³ /min	
Working pressure	0.2Mpa	
Rotor speed	12.3rpm	
Rotor size	14.5 liters	
Theoretical output ^①	10m ³ /h	
Recommended hose size	D64mm	
Max. aggregate size	20mm	
Max. conveying distance horizontal/vertical	Dry: 200m/100m	
	Wet: 40m/15m	
Dimensions	Length	1950mm
	Height	1375mm
	Width	856mm
Weight	1000Kg	
^① Based on a theoretical filling level of 100%. Prior to use or processing, always consult the current product data sheet of the products used.		

◆ Detail part

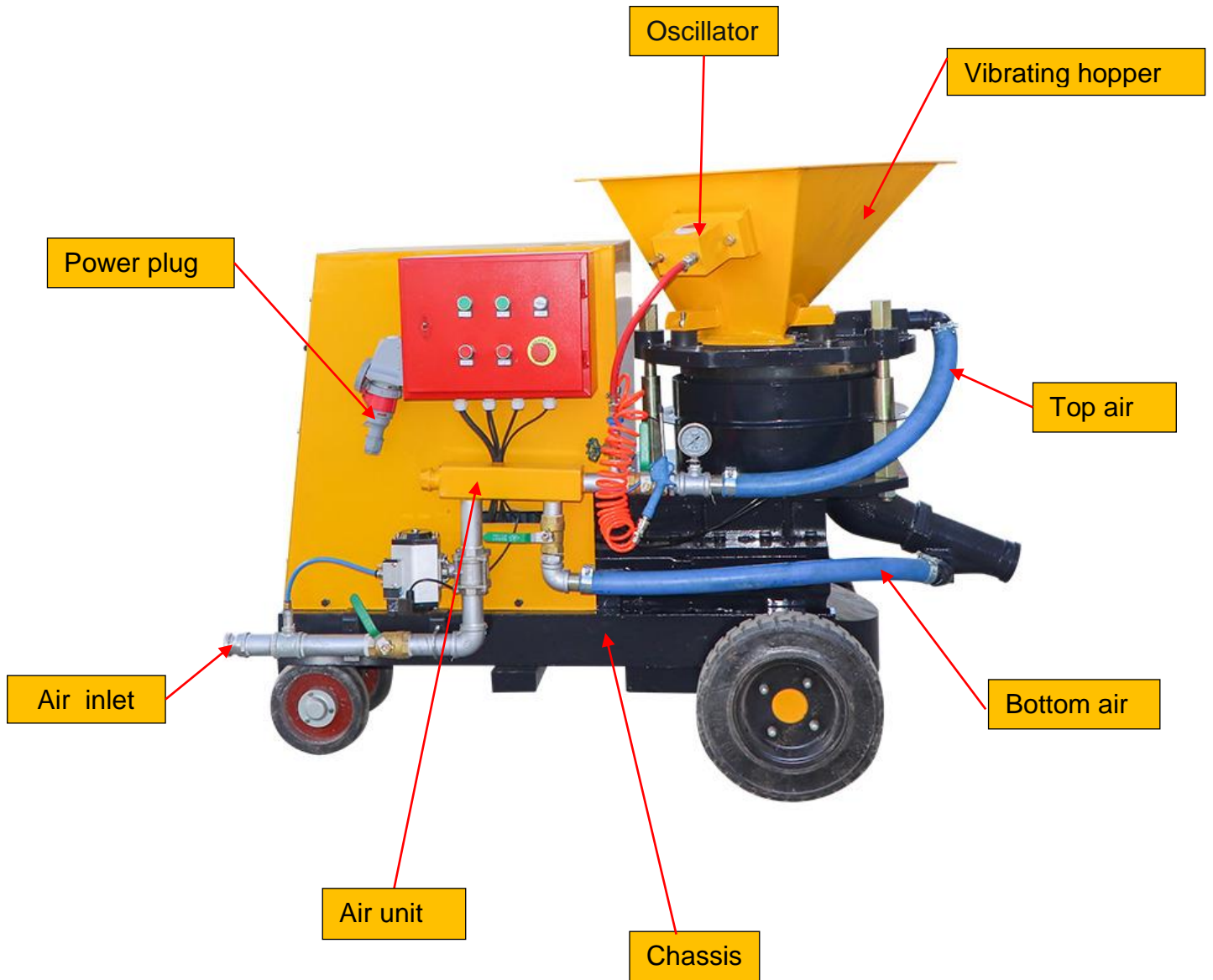



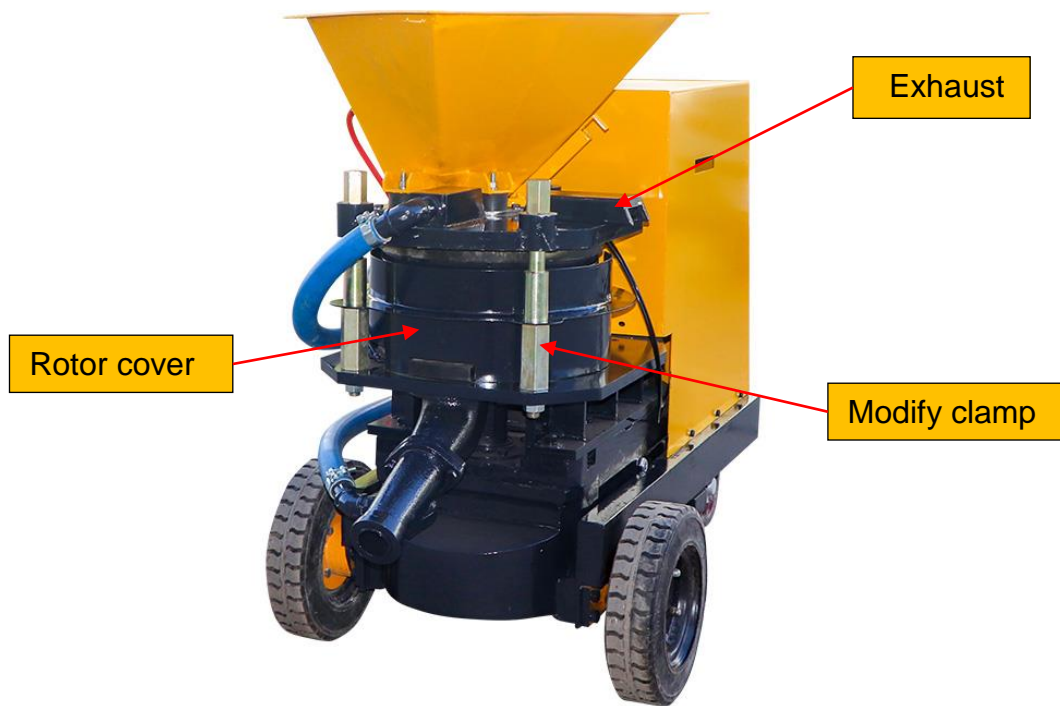



Zhengzhou Lead Equipment Co., Ltd.

Add: Xisihuan Ring-Road East, Tielu, Xiliu lake sub-district,
Zhongyuan District, Zhengzhou, Henan

Web: <https://www.leadcrete.net>

E-Mail: sales1@leadcrete.com