

## LZ-9E/S Rotary shotcrete machine for pea gravel backfilling

### Powerful, Compact and Reliable

#### 1. Description

LZ-9E/S Media is a multifunctional rotor type machine for wet and dry spraying and conveying. The materials that can be transported and sprayed with this kind of machine are mainly as follows: concrete, gunite, mortar, refractory, masses, sand, fine gravel, and crushed stone.

Compared with the traditional spraying and conveying machine, LZ-9E/S Media has several advantages: hydraulic floating compression (pressure automatic compensation after the rubber sealing plate is worn), hydraulic lifting rotor body, automatic anti-blocking function, automatic lubrication, the local control mode and remote control function with PLC control system, which greatly enhance the degree of automation of the machine and increase the machine efficiency. Therefore, this machine is widely used in mines, tunnels, culverts, subways, hydropower projects, underground projects, etc.

#### 2. Features

LZ-9E/S Media is a straight chamber rotor type wet and dry spraying and conveying machine.

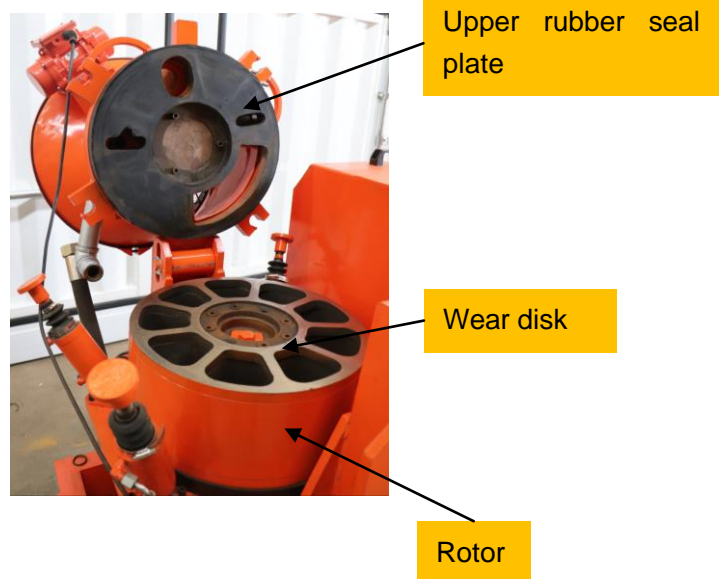
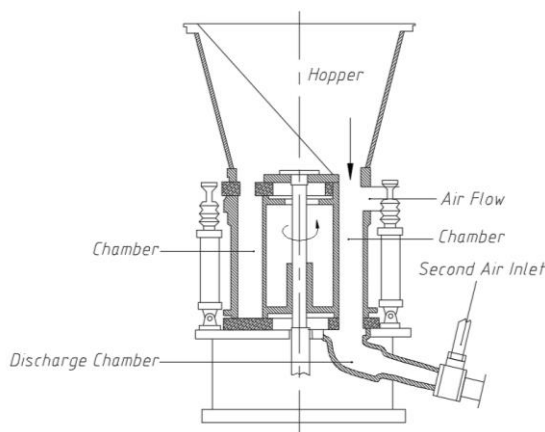

- ◆ Sector rigid wear plate and rotor
- ◆ High quality upper and lower rubber seal plates

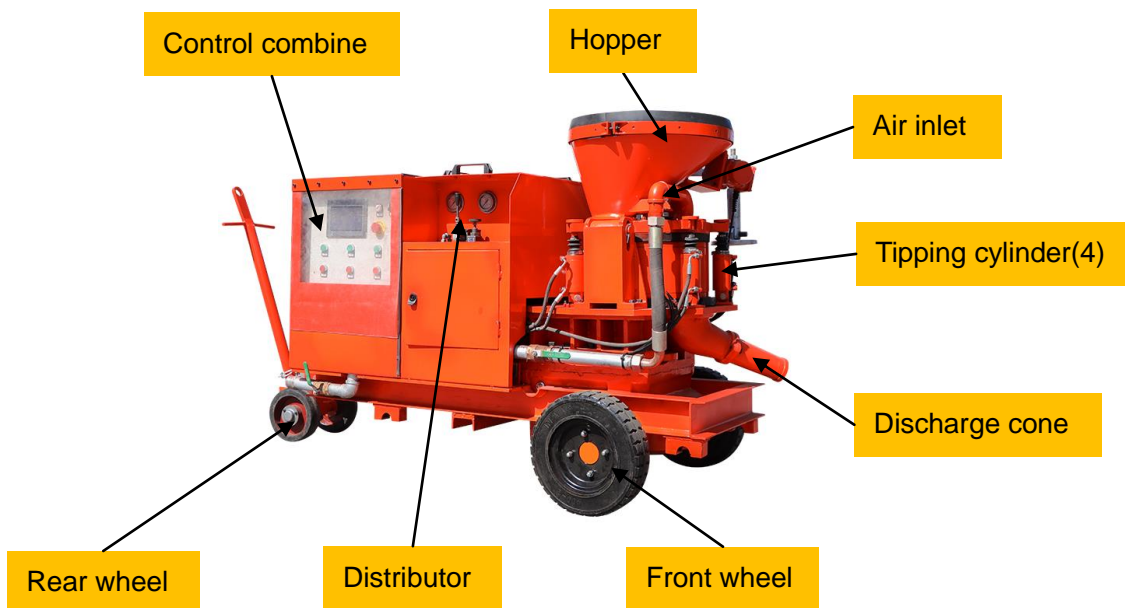

◆ Wheels

Heavy-duty solid wheels.

Steerable rear wheels.

Solid wheels can be replaced with track wheels as needed.

◆ Hydraulic System

Hydraulic floating compression (pressure automatic compensation after the rubber sealing plate is worn).

Hydraulic lifting rotor body.

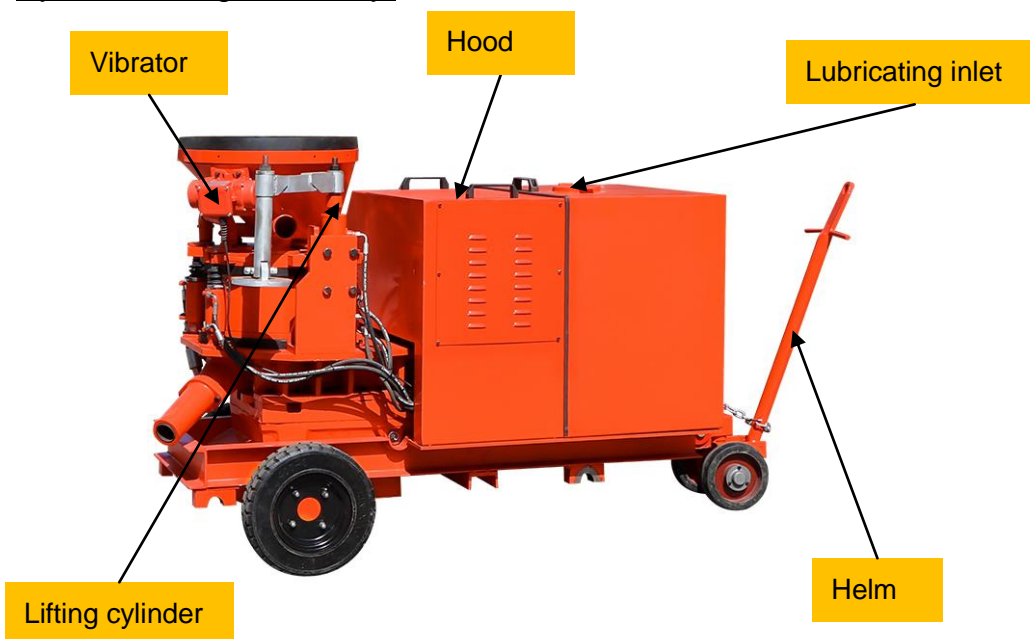

- ◆ Automatic lubrication  
Automatic lubrication for upper and lower seal plates.
- ◆ Control system  
Variable output with variable-frequency drive.  
PLC integrated machine control.  
Locally control mode and remote control function.
- ◆ Intelligent anti-clogging pipe system

### 3. Technology Sheet

<b>Specification (with Electric motor drive):</b>		
1. Automatically clean delivery line blockage: PLC+VFD+Air Pressure Sensor		
2. Sector hole to replace the circle hole in the rotor to improve the volume of the rotor and to decrease friction area, then with the same output, the rotor speed will be lower to improve the work life of the rubber sealing plate and keep the motor power lower.		
3. Hydraulic floating compression (pressure automatic compensation after the rubber sealing plate is worn).		
4. To add an automatic lubricator to the rubber seal plate to make the work life of worn parts longer and make the motor power lower.		
5. Intelligent anti-clogging pipe system.		
Rotor Volume		12.9L
Max. Rotor Speed		12.6r/min
Max. Output ①		9.5m <sup>3</sup> /h
Max. Horizontal Conveying Distance		200m
Max. Aggregate Size		Φ 20 mm
Conveying Hose Inner Diameter		64mm
Operating Air Pressure		0.2-0.4MPa(29-58PSI)
Air Consumption		12-14m <sup>3</sup> /min(215-250CFM)
Rotor Motor	Power	7.5kW
	Voltage	3 phase, 380V, 50Hz
Hydraulic System	Power	0.37Kw
	Voltage	3 phase, 380V, 50Hz
Automatic Lubrication	Volume	4L
	Power	24V, 50w
Vibration Motor	Power	0.04Kw
	Voltage	3 phase, 380V, 50Hz
Dimension(L×W×H) (heavy-duty solid wheels)		2200×960×1300mm
Weight(heavy-duty solid wheels)		1425kg
① Data is based on safe filling and complete emptying of the cylinder.		
We could also customize according to your demands.		

#### 4. Machine Pictures Gallery









## Zhengzhou Lead Equipment Co., Ltd.

Add : Xisihuan Ring-Road East, Tielu,Xiliu lake sub-district, Zhongyuan District, Zhengzhou, Henan

P.C.: 450042

Web: [www.leadcrete.net](http://www.leadcrete.net)

Email: [sales1@leadcrete.com](mailto:sales1@leadcrete.com)